

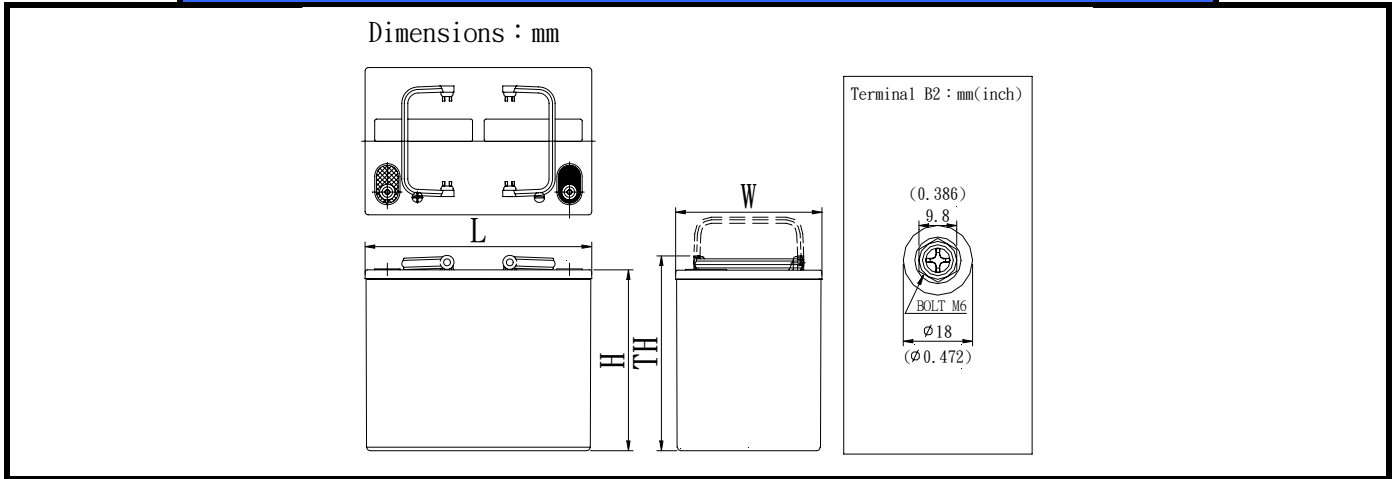

統一工業電池規格書

電池型式(BATTERY TYPE) : TEV12750



1. 尺寸(Dimensions):

項目 (Item)	規格值 (Specifications)
1. 長 (Length)	260±2mm (充電後 Max : 265mm)
2. 寬 (Width)	168±2 mm
3. 高 (Height)	207±2 mm
4. 總高 (Total Height)	223±2 mm

2. 性能測試 (Performance):

項目 (Item)	規格值 (Specifications)				
1. 電壓 (Nominal Voltage)	12 V				
2. 重量 (APPROX. Weight)	26.0 Kgs				
3. 自行放電特性 Shelf Life (25°C)	1月 (1 Month)	97% ↑			
	3月 (3 Month)	90% ↑			
	6月 (6 Month)	80% ↑			
4. 放電容量 (Discharge Capacity)	放電電流	終止電壓	放電時間	放電電量	
	20HR 容量 (20hr Capacity)	3.75A	10.50 V	20hrs ↑	75.00AH ↑
	5HR 容量 (5hr Capacity)	12.75A	10.20 V	5hrs ↑	63.75AH ↑
	3HR 容量 (3hr Capacity)	17.50A	10.20 V	3hrs ↑	52.50AH ↑
	1HR 容量 (1hr Capacity)	45.00A	9.60 V	1hrs ↑	45.00AH ↑
5. 壽命試驗 (Life of Cycle Use)	100 % 深放電 (100% Depth of Discharge)	200 CYCLES ↑			
	50 % 深放電 (50% Depth of Discharge)	400 CYCLES ↑			
	30 % 深放電 (30% Depth of Discharge)	1200 CYCLES ↑			

3.定功率放電特性(Constant Power Discharge Characteristics)

Time F.V	5Min.	7.5Min.	10Min.	15Min.	20Min.	30Min.	60Min.
9.6 V	3132 W	2741 W	2344 W	1825 W	1485 W	1181 W	707 W
10.2 V	2738 W	2452 W	2183 W	1790 W	1449 W	1163 W	698 W
10.8 V	2362 W	2130 W	1915 W	1593 W	1342 W	1091 W	662 W

4.性能特性圖(Characteristics)

1.放電時間與放電電流的關係
(Discharge Time VS Discharge Current)

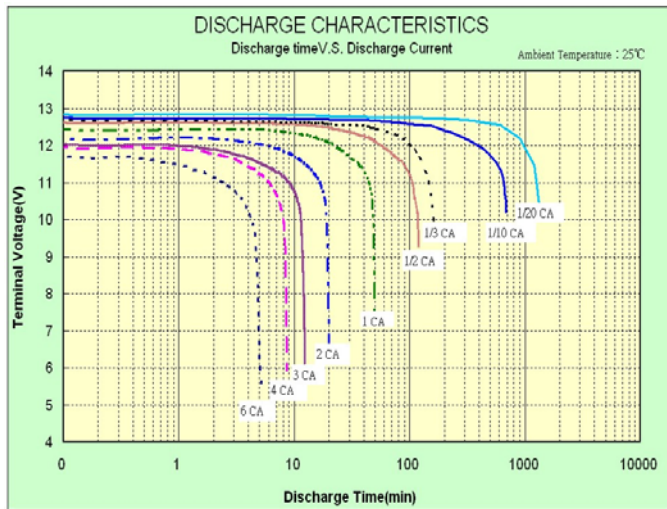

2.循環使用壽命之特性
(Life Characteristics of Cycle Use)

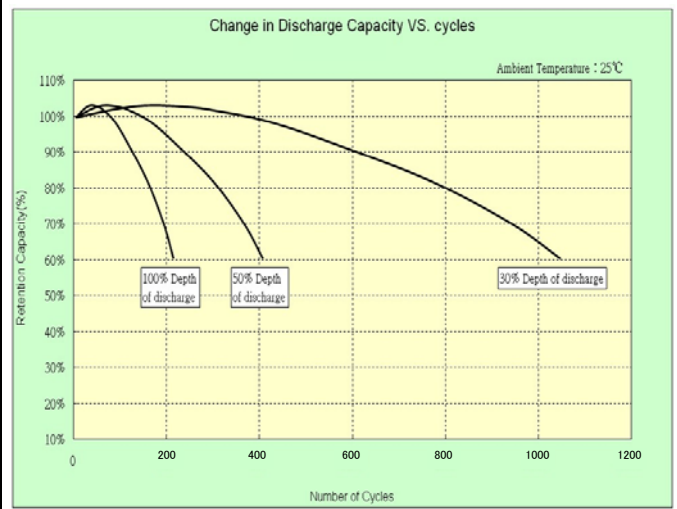

3.開路電壓與容量保存的關係
(Open Circuit Voltage and Capacity Remainder)

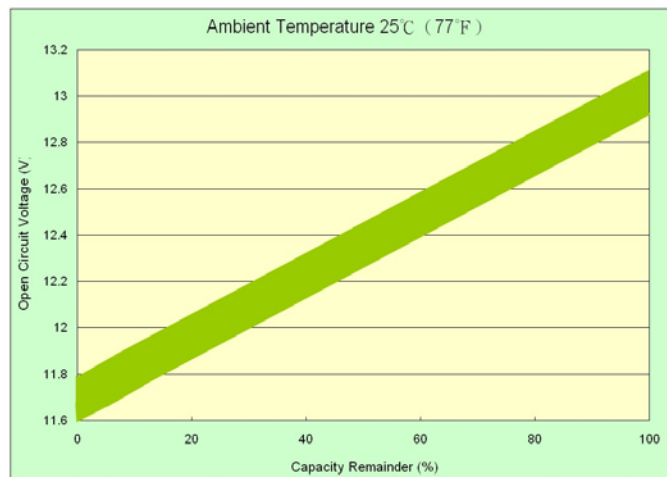

4.放電負載與放電時間的關係
(Discharge Characteristics of Constant Load)

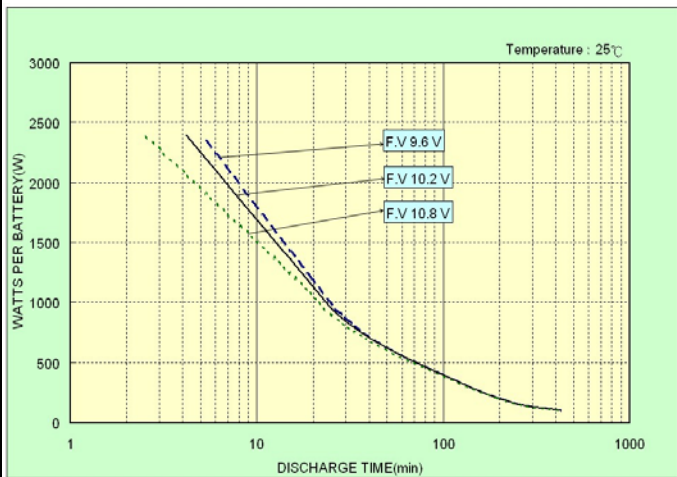

5.國際認證(International Certification)

- (1).ISO 9001 , QS9000 , TS16949
- (2).UL approval , Code : MH13567

